

SVCam-svs29050

SVCam-HR Series

Compact 29 Megapixel Camera



A highend resolution of 6.576 x 4.384 pixel makes this digital Machine Vision camera „best in class“. Combined with Kodak 4-Tap Technology it is a real masterpiece of German Engineering.

Correlated Double Sampling (CDS) and 4 x 14 Bit A/D converters guarantee an excellent signal-to-noise ratio.

The internal logic allows different ways to adjust exposure time and select trigger modes including:

- > Synchronization of image capture to an external event (trigger mode)
- > “Free running” with maximum frame rate
- > Exposure time control via serial interface or by trigger pulse width
- > Longer exposure times up to under low light level conditions

The camera can work fully compliant with GigE Vision standard. In addition dual GigE complies with Static Link Aggregation (SLA) standard.



GEN<i>CAM

Technical Highlights/Technical Data

- > Progressive Scan technology
- > Resolution: 6.576 x 4.384 pixel
- > Synchronization:
 - “Free running” (frame rate adjustable)
 - External trigger with internal exposure control
 - External trigger with pulse width exposure control
 - Software trigger via PC
- > Housing dimensions: 70 mm x 71 mm x 52.7 mm
- > Monochrome and color sensors (Bayer Pattern)
- > 8 Bit (using 14 Bit ADC)
- > 128 MB Memory inside
- > Pixel defect correction
- > Internal shading correction
- > Adjustable gain
- > Auto tap balancing
- > Low offset
- > Area Of Interest (AOI)
- > M58 x 0.75 Mount (optional F-Mount adapter)
- > Broad voltage input possible (+10V to +25V DC)
- > Operating temperature range: -10°C to +40°C
- > Full 2 years warranty

Overview

SVCam-svs29050	GigE Version
Camera Type	svs29050XFLGEA
Resolution	6.576 x 4.384
Frame Rate (Hz, max.)	6.2
Pixel (μm^2)	5.5 x 5.5
CCD-Size Equivalent	43.47 mm diag.
Exposure Time internal	17 μs - 60 s
Exposure Time external	17 μs - ∞

X = Monochrome, X = Color
Cameras make use of high performance CCD made by **Truesense Imaging, Inc.**®, formerly **Kodak** (USA). For more camera types see our SVCam-HR product overview.

Operation Modes

Mode: Free Running/Fixed Frequency

In this mode the camera creates all sync signals itself. Camera is connected to PC and will create images immediately.

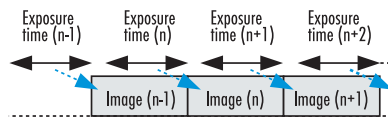

Mode: External Trigger, Internal Exposure Control

The camera needs an external trigger to output images. The exposure time is set by the internal logic inside the camera.

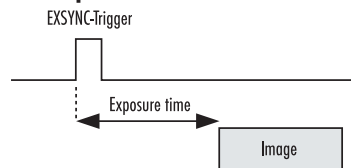

Mode: External Trigger, External Exposure Control

The camera needs an external trigger to output images. The exposure time is determined by the pulse width of the trigger signal and can be changed from frame to frame.

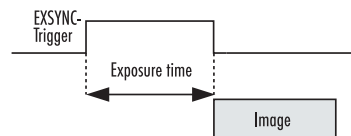

Mode: Software Trigger (GigE only)

The PC sends a command to the camera in order to get data. Internal logic is set for the exposure time. Jitter must be observed.

Dimensions [mm]

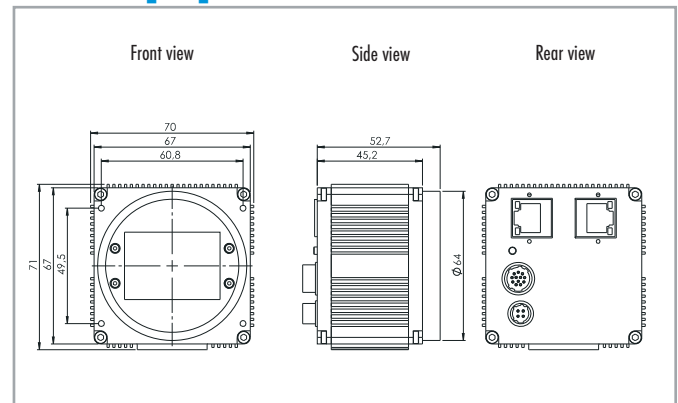

Connector pin-out

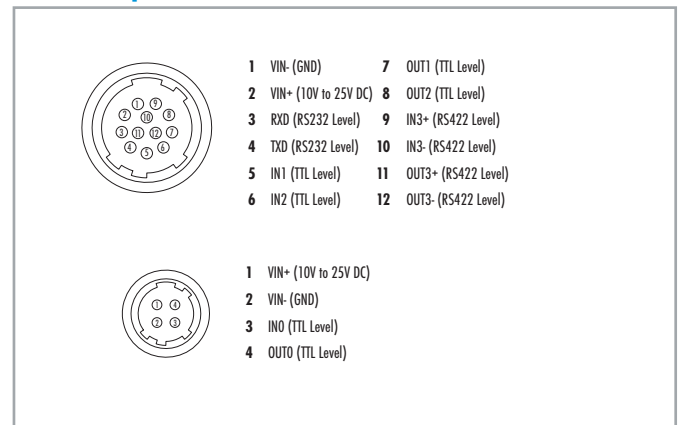

Ordering Guide

Monochrome: **svs29050MFLGEA** Color: **svs29050CFLGEA** (max. 6.2 Hz / 8 Bit)

Option: M58 to F-Mount adapter

Configuration Software

The SVCam cameras come with our "SVCapture"-software, which allows easy interactive setup of all camera parameters. The program runs under Windows XP/7 but also 64 Bit mode. Linux is supported as well. A XML file compliant with the GenICam standard is supplied with the camera. The free SDK and API coming with the camera allows easy integration into an application without involving a frame grabber.

