

ProScan™ Stages for Zeiss

PRIOR
Scientific

114mm x 75mm Travel, Flat Top Motorised Scanning Stage for the AxioVert 200 and AxioObserver Inverted Research Microscopes from Zeiss.

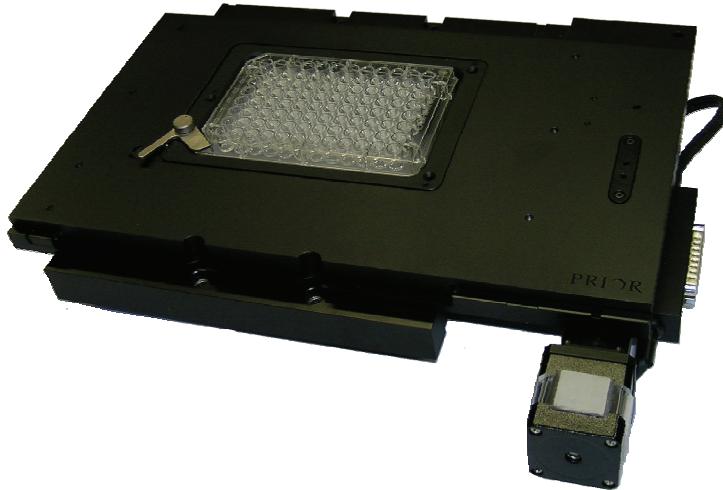

The H117 family of flat top stages for inverted research microscopes set new standards for convenience and performance. Designed to seamlessly integrate with other items such as micro-manipulators and incubation chambers, the top surface of the stage is completely free of obstruction. This provides a highly ergonomic platform with exceptionally easy access to the sample area.

H117 Features:

- Travel Range 114mmx75mm
- Intelligent Scanning Technology, IST
- Flat Top Design
- <1µm Resolution
- +/-0.7µm Repeatability
- Interchangeable Sample Holders
- Choice of High Precision Ball Screw
- Anti-Backlash Mechanism
- Adjustable Limit Switches
- Choice of Motor Type
- Accepts Linear Encoders
- Compatible with Definite focus system
- Controlled in most imaging software

Dimensions

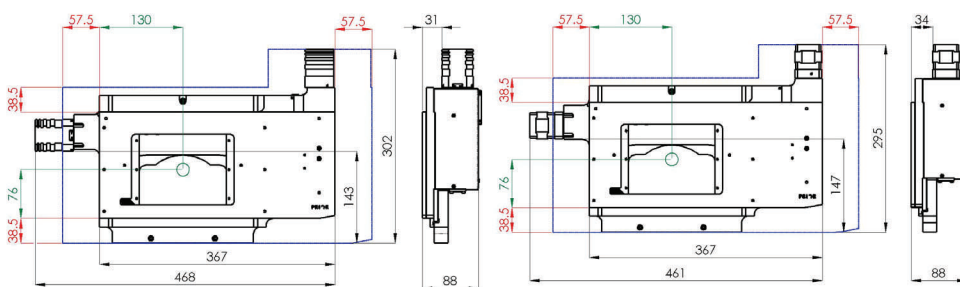

X2 version Type 1

X4 versions Type 2

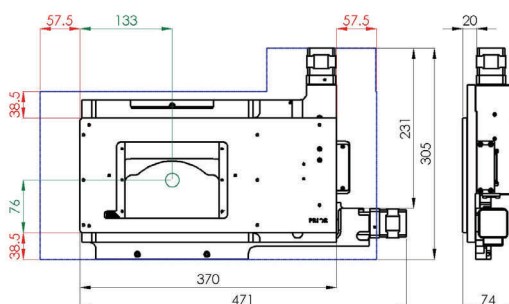

L4 Version for Zeiss Observer with Definite focus Type 2

Prior motorised stages have a reputation for quality and performance. As an ISO 9001:2000 accredited company Prior equipment is designed and manufactured to the highest quality standards. Prior provides full support and service both direct and indirect through a professional, knowledgeable and extensive global dealer network.

GB Patent No. 2411249

US Patent No. 7330307

Specifications

	HI17N2X2	HI17N1X2	HI17N1X4 HI17N1L4	HI17E2X2	HI17E1X2	HI17E1X4 HI17E1L4	Units
Performance							
**Bi-Directional Repeatability (Average Performance)	+/- 2.2(1.3)	+/- 2.0 (1.0)	+/- 2.0(0.9)	+/- 1.5 (0.8)	+/- 1.5 (0.8)	+/- 1.5 (0.6)	um
**Uni-Directional Repeatability (Average Performance)	+/- 0.7 (0.2)	+/- 0.7 (0.2)	+/- 0.7 (0.2)	+/- 0.7 (0.2)	+/- 0.7 (0.2)	+/- 0.7 (0.2)	um
Minimum Step Size	0.04	0.02	0.01	0.04	0.02	0.01	um
Recommended Speed (Maximum Speed)	40 (100)	20 (50)	15 (25)	40 (100)	20 (50)	15 (25)	mms ⁻¹
*Metric Accuracy (per mm of travel) (Average Performance)	0.2 (0.06)	0.2 (0.059)	0.2 (0.059)	0.2 (0.057)	0.2 (0.046)	0.2 (0.046)	um
Specifications							
Maximum Travel Range	114x75	114x75	114x75	114x75	114x75	114x75	mm
Maximum Load	10	10	10	10	10	10	kg
Squareness	30	30	30	30	30	30	arc sec
Weight	5	5	5	5	5	5	kg
Type	1	1	2	1	1	2	
Ball Screw Pitch	2	1	1	2	1	1	mm
Motor Type	200	200	400	200	200	400	***S.P.R
Encoders	No	No	No	0.1	0.1	0.1	um res

Requires the use of a Prior ProScan II or above controller and are based on Prior method of testing.

*Based on performance with IST enabled, and measured over the full travel of stage.

**Using a Prior ProScan controllers with backlash correction enabled, all repeatability is Uni-directional.

***S.P.R: Full steps per revolution of motor.

Controller Options



Patented Intelligent Scanning Technology (IST):

The ProScan™ III controller and stage include as standard IST which significantly improves the metric accuracy of the ProScan™ stage.

ProScan™ III Ordering Information:

V31XYZ for Stage and Focus control order and

V31XYZE for encoded stages.

To add functionality for Filter wheels and shutter

V31XYZF and **V31XYZEF** for encoded stages.

For the horizontally stacking version use **H** as the first character of the part numbers above.

Dimensions: 177x177x177mm (4U)

Prior Interactive Control Centre.

PS3J100 local control centre provides positional feedback and the ability to measure distances. The stage can be controlled either via the Joystick or via fine individual X and Y control knobs.



CERTIFICATE NO: FM 61600
STANDARD: BS EN ISO 9001:2000

Prior Scientific Limited
Cambridge, UK.
T. +44 (0) 1223 881711
E. uksales@prior.com

Prior Scientific GmbH
Jena, Germany.
T +49 (0)3641 675 650
E. jena@prior.com

Prior Scientific Inc.
Rockland, MA, USA.
T. +1 781-878-8442
E. info@prior.com